

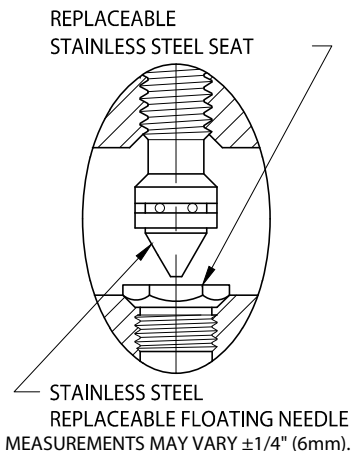

CT3180-141WSA

NEEDLE VALVE ASSEMBLY, PANEL MOUNTED DOUBLE

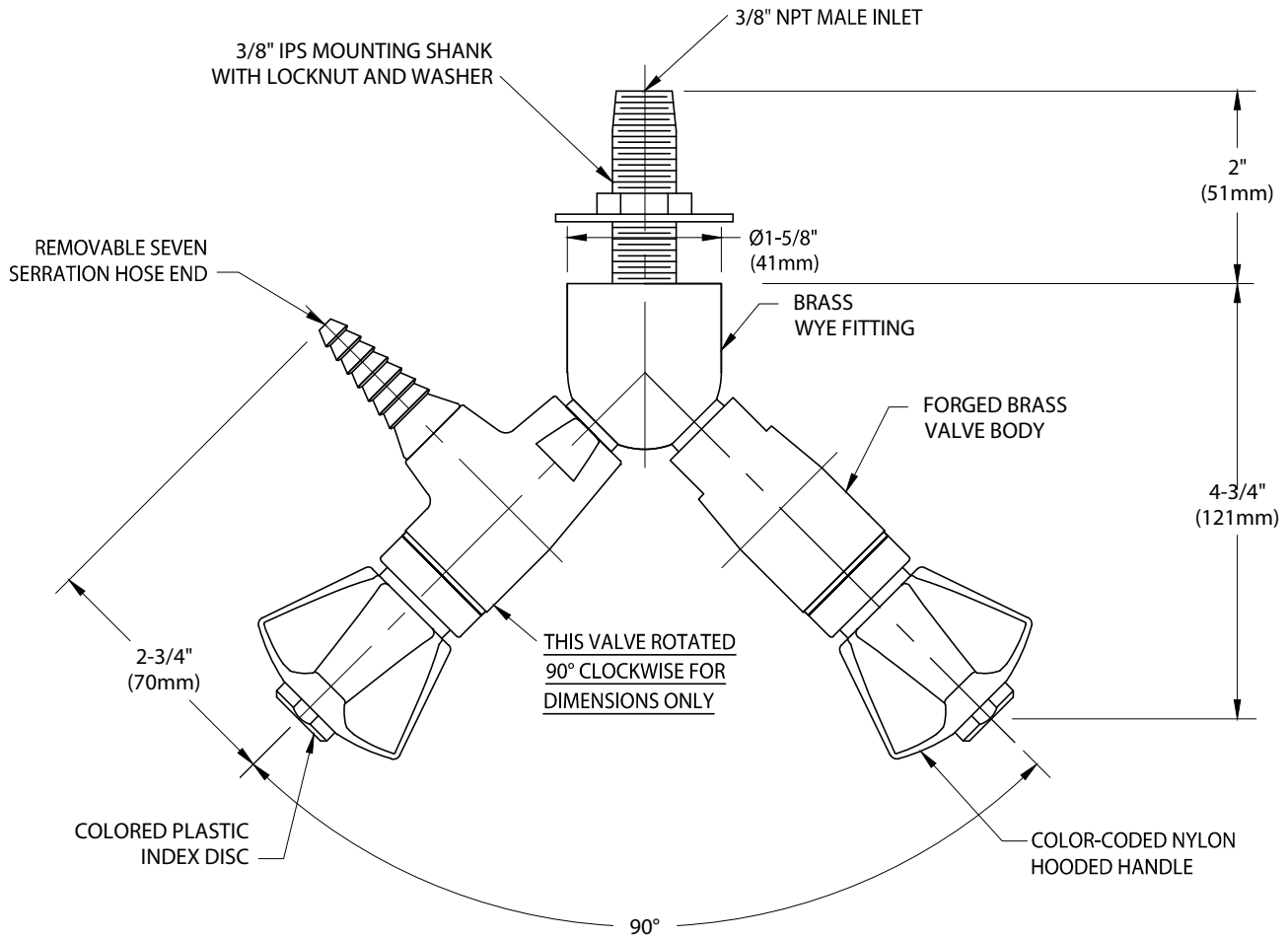

NOTES:

1. FURNISHED WITH MOUNTING SHANK, LOCKNUT AND WASHER FOR SECURING FIXTURE TO PANEL.
2. VALVE IS CERTIFIED BY CSA INTERNATIONAL TO COMPLY WITH ANSI Z21.15 AND CGA 9.1.
3. VALVE IS FULLY ASSEMBLED AND FACTORY TESTED AT 250 PSI NITROGEN PRESSURE. MAXIMUM WORKING PRESSURE IS 150 PSI.
4. SPECIFY IF CLEANING FOR OXYGEN AND HIGH PURITY GASES IS REQUIRED.
5. FIXTURE HAS COLORTECH EPOXY POWDER COATED FINISH. SPECIFY COLOR (WHITE, GRAY OR TAN) WHEN ORDERING.

