

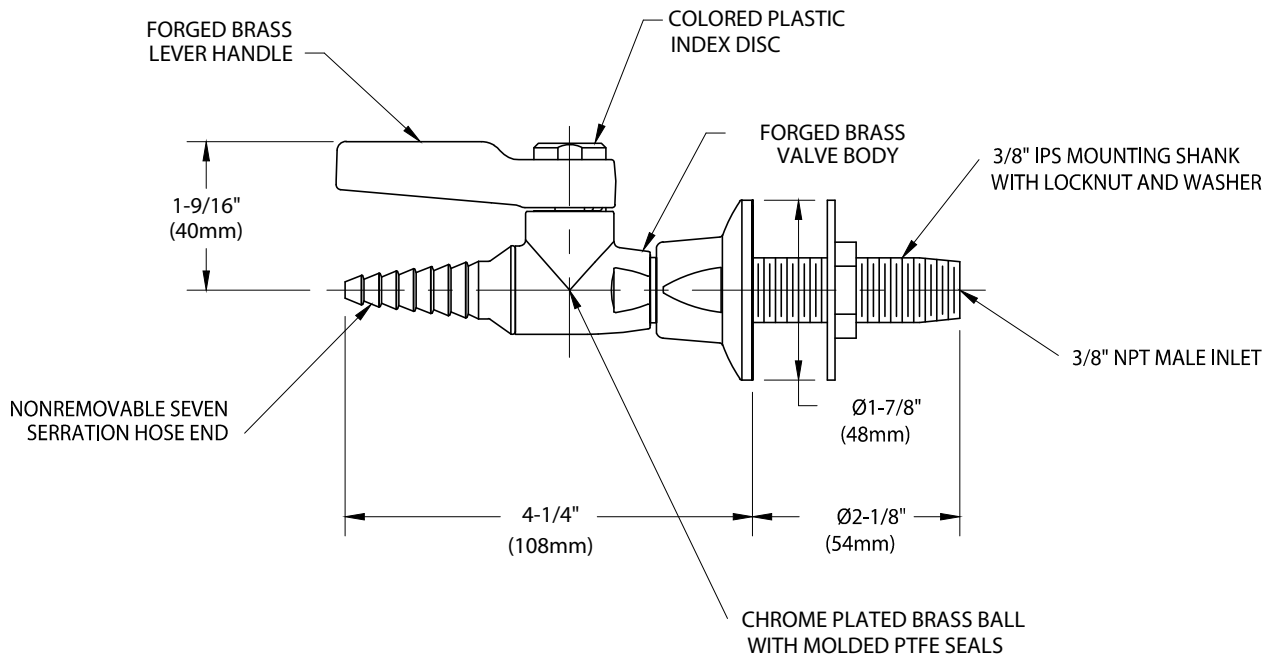

CT4100-158WSA

LABORATORY BALL VALVE ASSEMBLY, PANEL MOUNTED SINGLE



NOTES:



- LABORATORY BALL VALVE ASSEMBLY IS CERTIFIED BY CSA INTERNATIONAL TO COMPLY WITH ANSI Z21.15 AND CGA 9.1.
- FIXTURE IS FULLY ASSEMBLED AND FACTORY TESTED AT 125 PSI AIR PRESSURE. MAXIMUM WORKING PRESSURE IS 75 PSI.
- SPECIFY IF CLEANING FOR OXYGEN AND HIGH PURITY GASES IS REQUIRED
- FIXTURE HAS COLORTECH EPOXY POWDER COATED FINISH. SPECIFY COLOR (WHITE, GRAY OR TAN) WHEN ORDERING.

MEASUREMENTS MAY VARY ±1/4" (6mm).