



# WaterSaver

## ColorTech

### CT4880F-225WSA

NEEDLE VALVE ASSEMBLY, PANEL MOUNTED

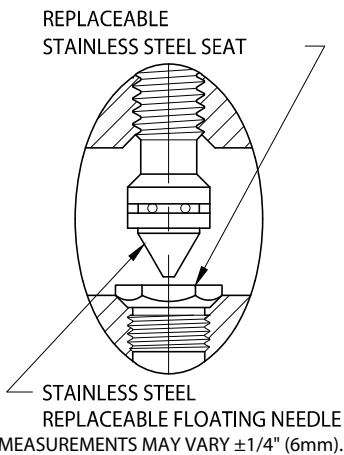
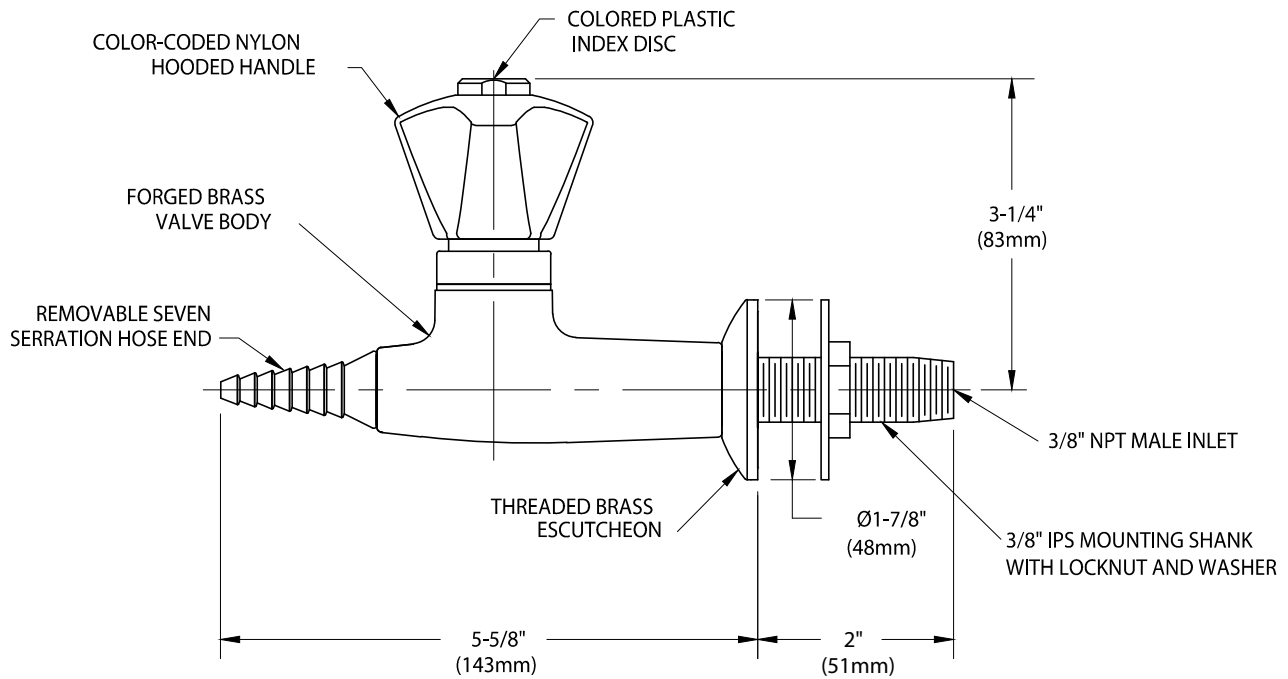

#### NOTES:

1. FURNISHED WITH THREADED ESCUTCHEON, MOUNTING SHANK, LOCKNUT AND WASHER FOR SECURING TO PANEL.
2. VALVE IS CERTIFIED BY CSA INTERNATIONAL TO COMPLY WITH ANSI Z21.15 AND CGA 9.1.
3. FIXTURE IS FULLY ASSEMBLED AND FACTORY TESTED AT 250 PSI NITROGEN PRESSURE. MAXIMUM WORKING PRESSURE IS 150 PSI.
4. SPECIFY IF CLEANING FOR OXYGEN OR OTHER PURE GAS SERVICE IS REQUIRED.
5. FIXTURE HAS COLORTECH EPOXY POWDER COATED FINISH. SPECIFY COLOR (WHITE, GRAY OR TAN) WHEN ORDERING.

