

EW819 Eyewash, Wall Mounted, Less Bowl



Application: Eyewash for wall mounting. Two GS-Plus™ spray-type spray heads deliver a flood of water for rinsing eyes. Unit is provided without bowl or drain for waste water. *Note: Floor drain should be provided underneath unit to prevent accumulation of water on floor.*

Spray Head Assembly: Two GS-Plus™ spray heads. Each head has a “flip top” dust cover, internal flow control and filter to remove impurities from the water flow.

Valve: 1/2" IPS chrome plated brass stay-open ball valve. Valve is US-made with chrome plated brass ball and PTFE seals.

Mounting: Heavy duty aluminum wall bracket with corrosion resistant powder coated finish.

Construction: Polished chrome plated brass.

Supply: 1/2" NPT female inlet.

Sign: ANSI-compliant identification sign.

Quality Assurance: Unit is completely assembled and water tested prior to shipment.

Available Options

- TM6020** Thermostatic mixing valve precisely blends hot and cold water to deliver tepid water as required by ANSI Z358.1-2014. Refer to “Thermostatic Mixing Valves” section for complete technical and product selection information.
- HS** Auxiliary hand-held drench hose for rinsing eyes, face or body.

EW819 Eyewash, Wall Mounted, Less Bowl

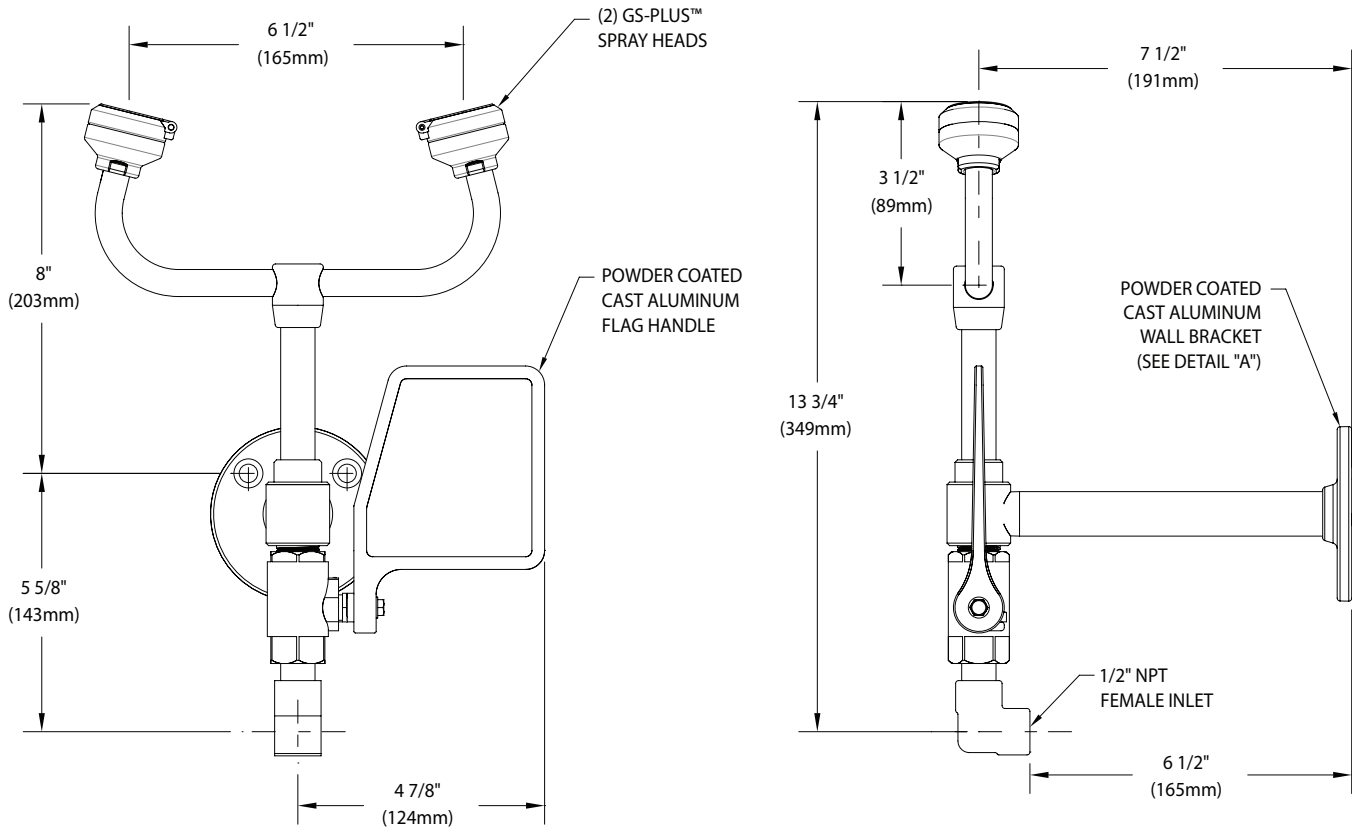

NOTES:

1. EACH GS-PLUS™ SPRAY HEAD HAS A "FLIP-TOP" DUST COVER, INTERNAL FLOW CONTROL AND FILTER TO REMOVE IMPURITIES FROM THE WATER FLOW.
2. UNIT SHOULD BE INSTALLED SUCH THAT WATER FLOW PATTERN IS POSITIONED BETWEEN 33" AND 53" ABOVE FLOOR.

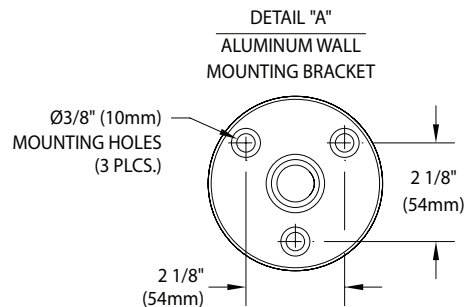

THIS SPACE FOR ARCHITECT/ENGINEER APPROVAL

Sign Included



Due to continuing product improvement, the information contained in this document is subject to change without notice. All dimensions are $\pm 1/4"$ (6mm). rev. 0522