

L2870-131WSA Fine Control Needle Valve Assembly, Deck Mounted Single

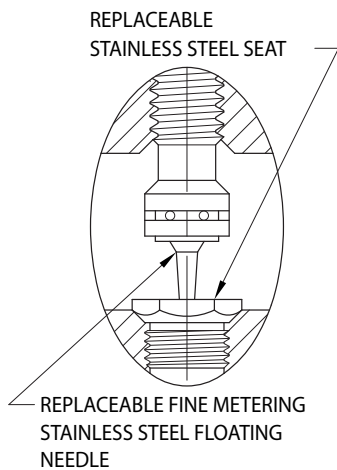
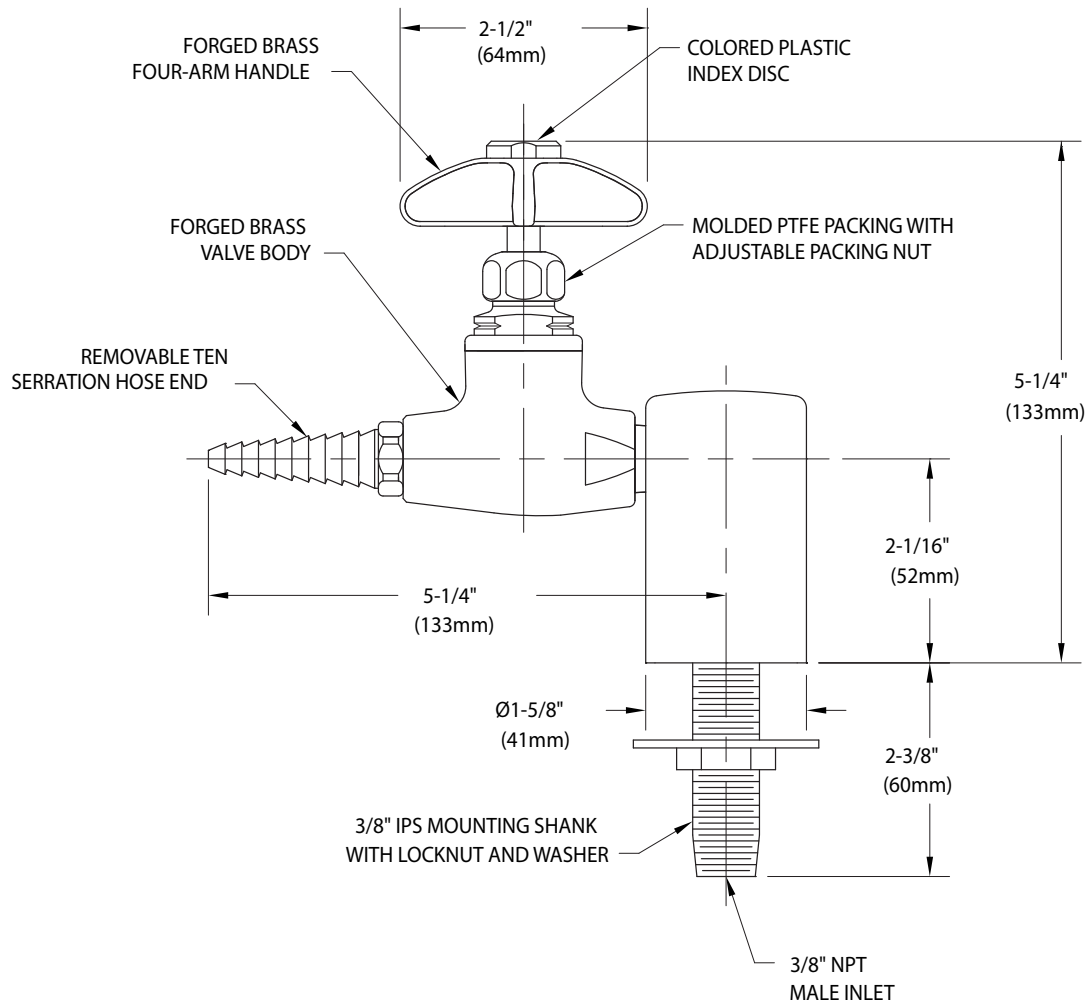

NOTES:

1. FIXTURE IS FULLY ASSEMBLED AND FACTORY TESTED AT 375 PSI NITROGEN PRESSURE. MAXIMUM WORKING PRESSURE IS 250 PSI.
2. FIXTURE IS CLEANED, DEGREASED AND PACKED FOR HIGH PURITY GAS SERVICE.
3. FIXTURE HAS A POLISHED CHROME PLATED FINISH.

Measurements may vary $\pm 1/4"$.