

○ **L2870-141WSA** Fine Control Needle Valve Assembly, Panel Mounted Double

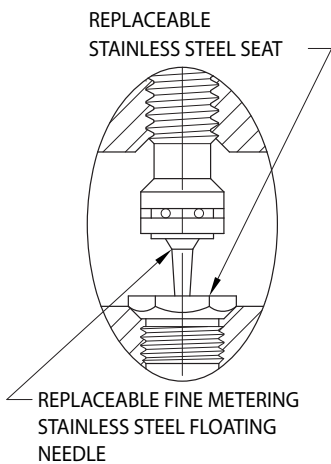
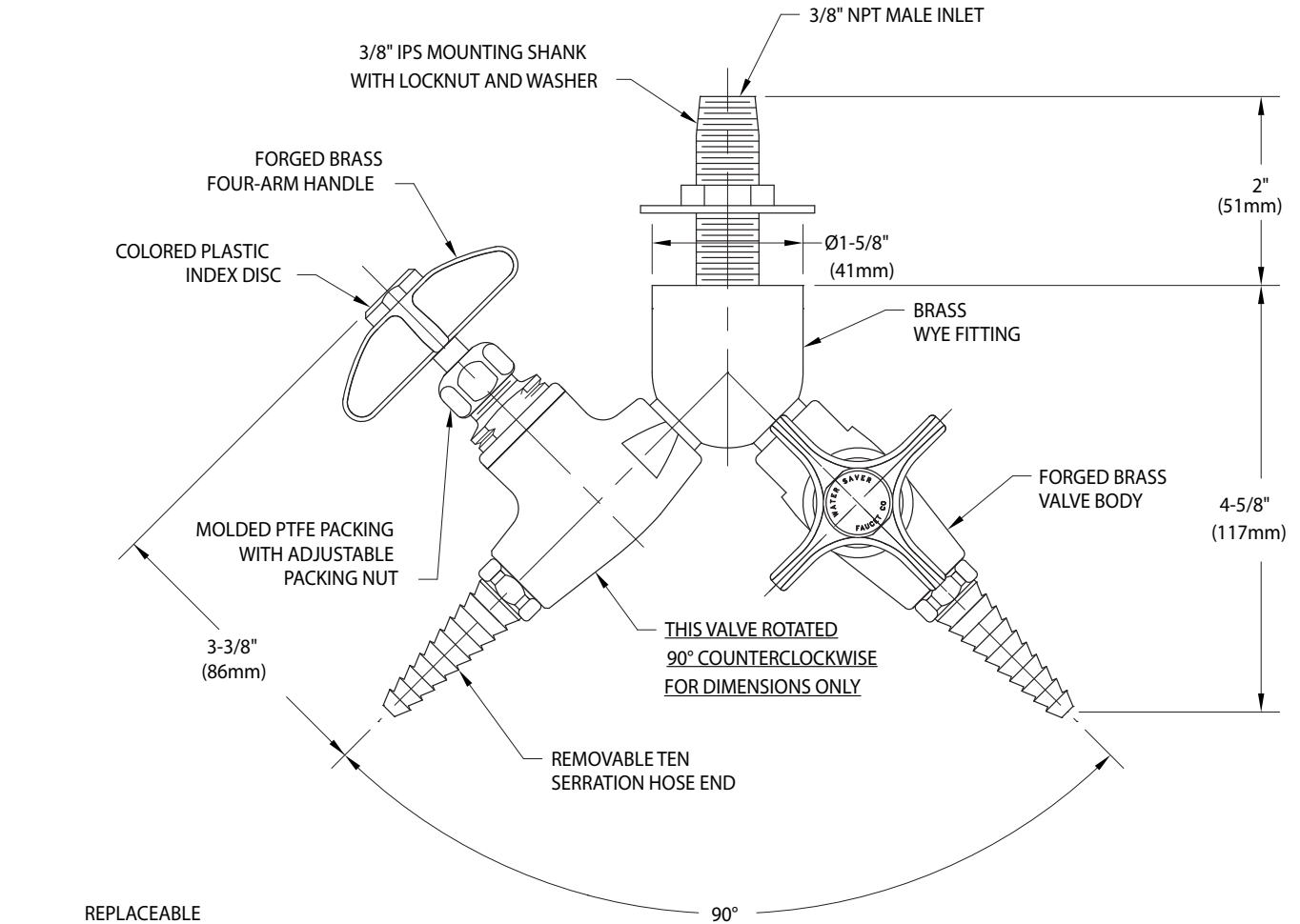

NOTES:

1. FURNISHED WITH MOUNTING SHANK, LOCKNUT AND WASHER FOR SECURING FIXTURE TO PANEL.
2. FIXTURE IS CLEANED, DEGREASED AND PACKED FOR HIGH PURITY GAS SERVICE.
3. FIXTURE IS FULLY ASSEMBLED AND TESTED AT 375 PSI NITROGEN PRESSURE. MAXIMUM WORKING PRESSURE IS 250 PSI.
4. FIXTURE HAS A POLISHED CHROME PLATED FINISH.

Measurements may vary $\pm 1/4$ ".