

### ○ L4100-141WSA Laboratory Ball Valve Assembly, Panel Mounted Double

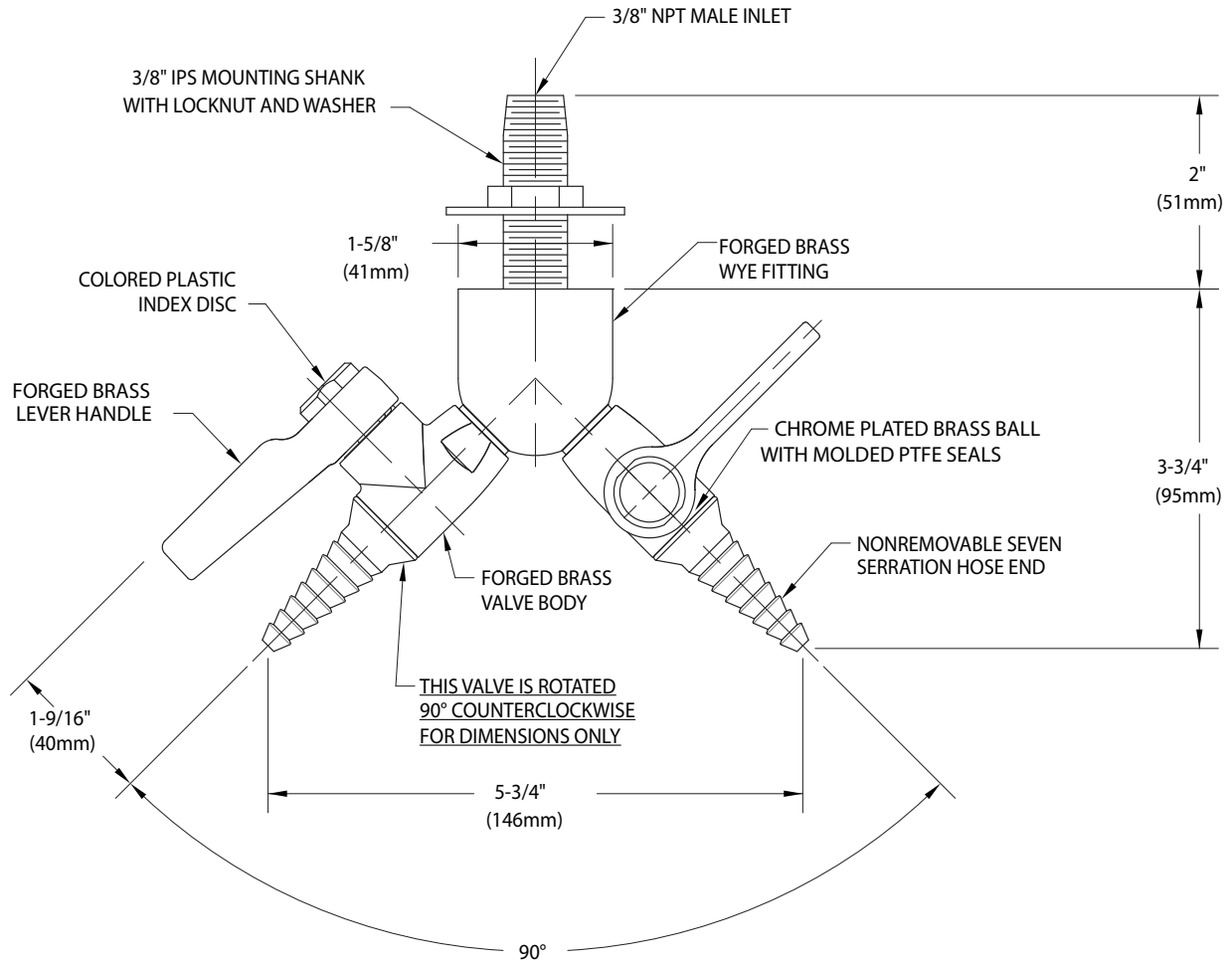

#### NOTES:



1. LABORATORY BALL VALVE ASSEMBLY IS CERTIFIED BY CSA INTERNATIONAL TO COMPLY WITH ANSI Z21.15 AND CGA 9.1.

2. FIXTURE IS FULLY ASSEMBLED AND FACTORY TESTED AT 125 PSI AIR PRESSURE. MAXIMUM WORKING PRESSURE IS 75 PSI.

3. SPECIFY IF CLEANING FOR OXYGEN AND HIGH PURITY GASES IS REQUIRED

4. FIXTURE HAS A POLISHED CHROME PLATED FINISH.

Measurements may vary  $\pm 1/4$ ".