

○ **L4100** Laboratory Ball Valve, Nonremovable Serrated Hose End

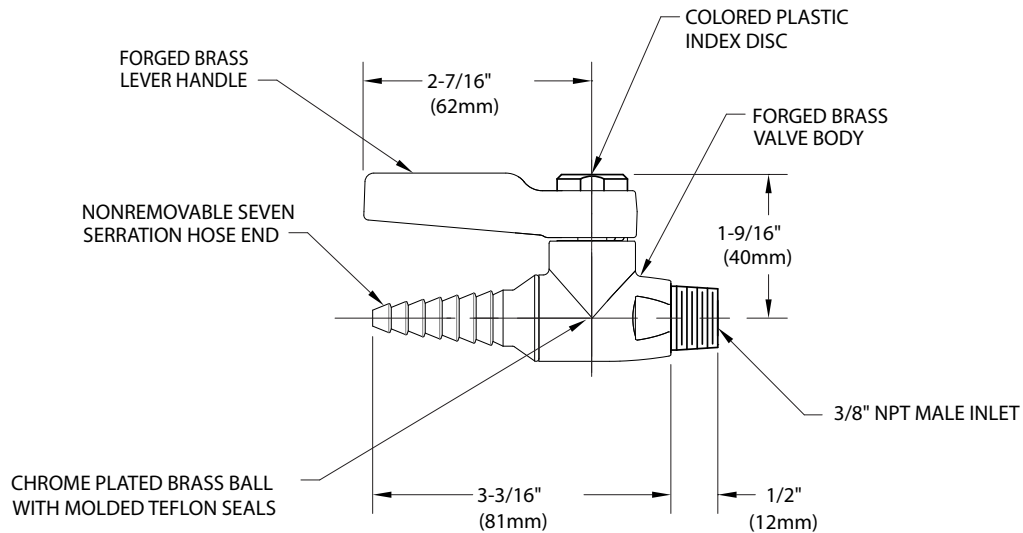

**NOTES:**



1. LABORATORY BALL VALVE IS CERTIFIED BY CSA INTERNATIONAL TO COMPLY WITH ANSI Z21.15 AND CGA 9.1.
2. VALVE IS FULLY ASSEMBLED AND FACTORY TESTED AT 125 PSI AIR PRESSURE. MAXIMUM WORKING PRESSURE IS 75 PSI.
3. SPECIFY IF CLEANING FOR OXYGEN AND HIGH PURITY GASES IS REQUIRED
4. VALVE HAS A POLISHED CHROME PLATED FINISH.

Measurements may vary  $\pm 1/4"$ .