

L3100 Laboratory Water Valve, Angle Pattern

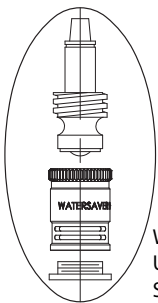

WATER SAVER RENEWABLE UNIT WITH REPLACEABLE STAINLESS STEEL SEAT

NOTES:

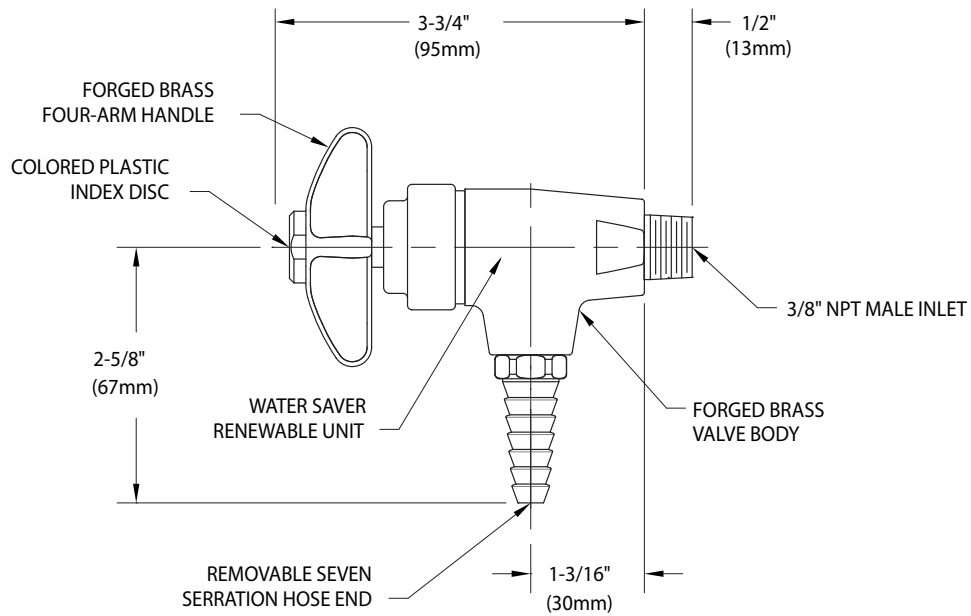

1. VALVE IS CERTIFIED BY CSA INTERNATIONAL TO COMPLY WITH ASME A112.18.1M AND CSA B125.1.
2. VALVE IS FULLY ASSEMBLED AND FACTORY TESTED PRIOR TO SHIPMENT.
3. VALVE HAS A POLISHED CHROME PLATED FINISH.

Measurements may vary $\pm 1/4"$.