

○ **L3100-141FT** Laboratory Water Valve Assembly, Wall Mounted Double, Floating Escutcheon

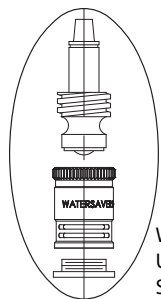

WATER SAVER RENEWABLE UNIT WITH REPLACEABLE STAINLESS STEEL SEAT

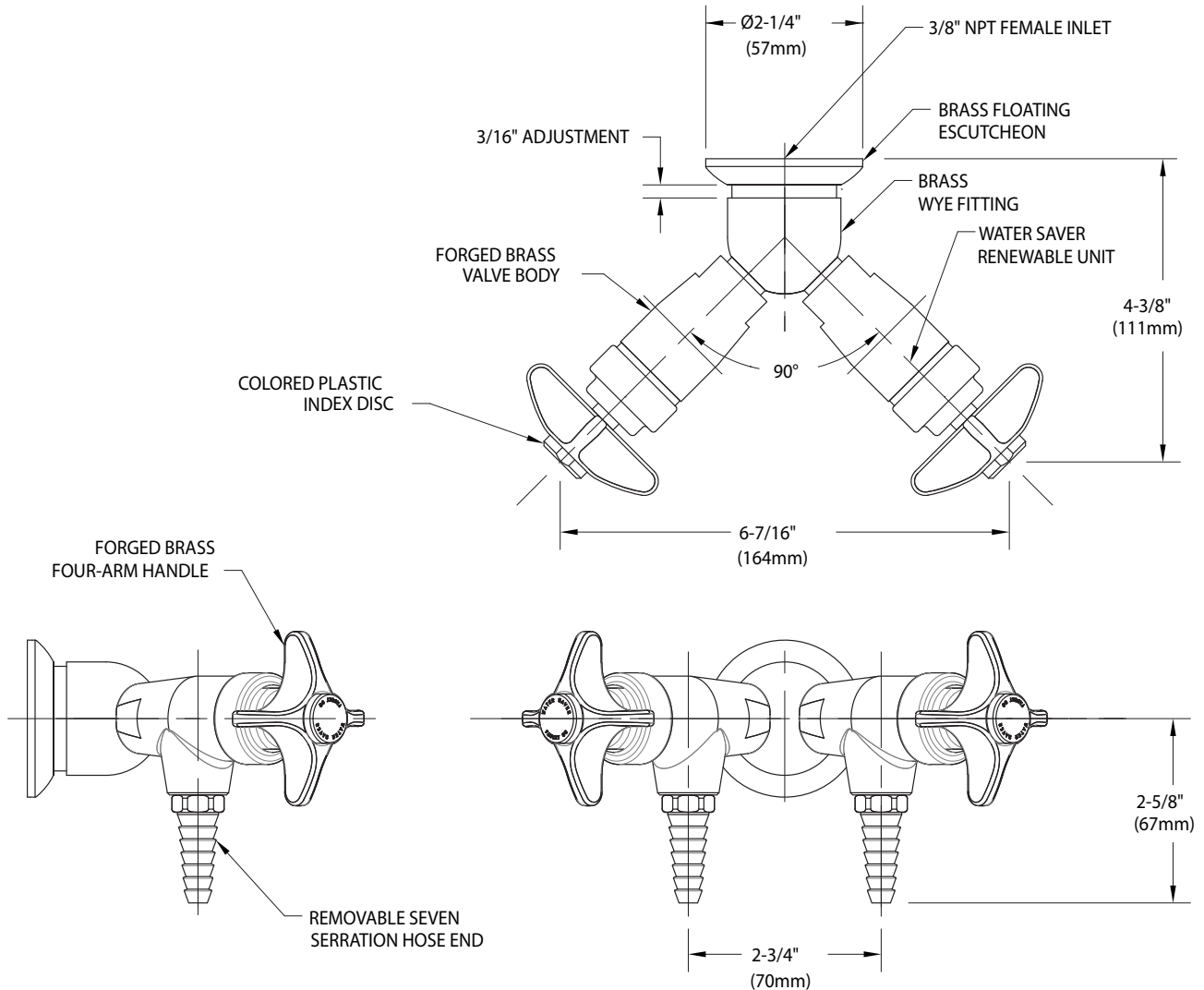

NOTES:

1. VALVE IS CERTIFIED BY CSA INTERNATIONAL TO COMPLY WITH ASME A112.18.1M AND CSA B125.1.
2. VALVE IS FULLY ASSEMBLED AND FACTORY TESTED PRIOR TO SHIPMENT.
3. FIXTURE HAS FEMALE INLET FOR CONNECTION TO SUPPLY. FLOATING ESCUTCHEON IS THREADED TO WALL TO CONCEAL ANY GAP BETWEEN FIXTURE AND WALL.
4. FIXTURE HAS A POLISHED CHROME PLATED FINISH.

Measurements may vary $\pm 1/4$ ".