

**L3180** Needle Valve, Angle Pattern

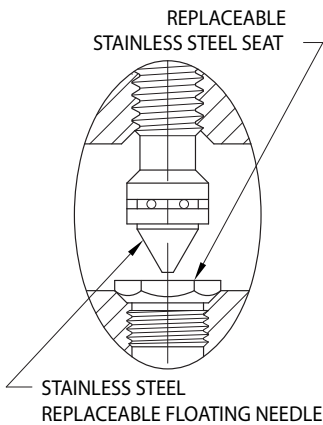

**NOTES:**

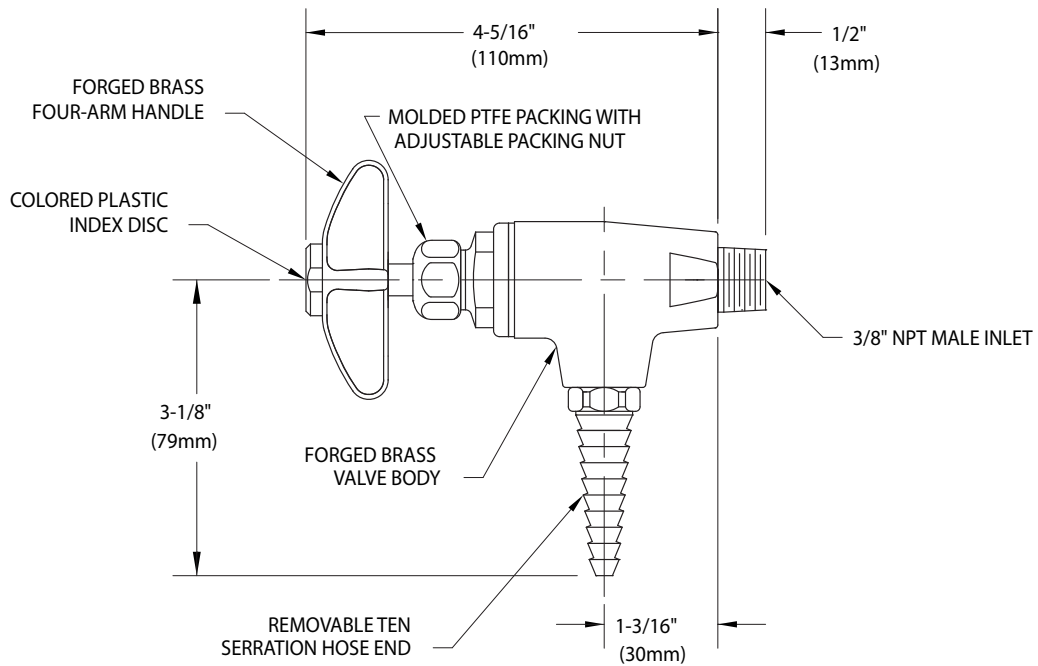

1. VALVE IS CERTIFIED BY CSA INTERNATIONAL TO COMPLY WITH ANSI Z21.15 AND CGA 9.1.
2. VALVE IS FULLY ASSEMBLED AND FACTORY TESTED AT 250 PSI NITROGEN PRESSURE. MAXIMUM WORKING PRESSURE IS 150 PSI.
3. SPECIFY IF CLEANING FOR OXYGEN AND HIGH PURITY GASES IS REQUIRED.
4. VALVE HAS A POLISHED CHROME PLATED FINISH.

Measurements may vary  $\pm 1/4$ ".