

Note: Please provide valve serial number (stamped on cover of valve) when ordering parts.

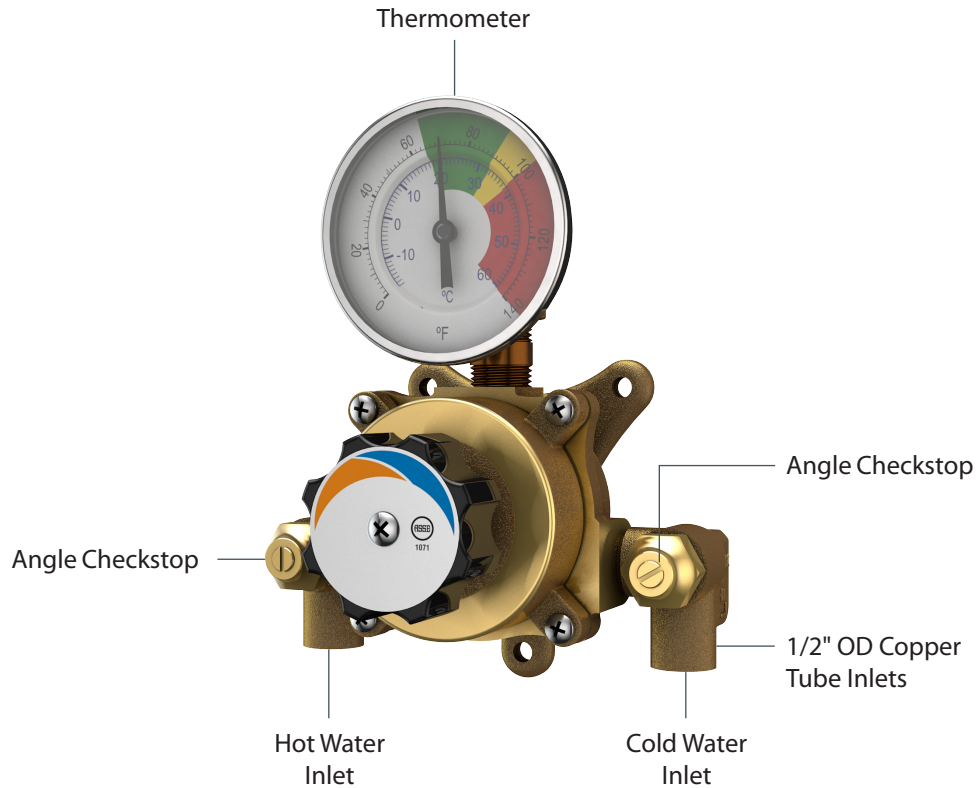

AP3600

Installation

1. Install valve in a location where it may be easily cleaned, adjusted or repaired.
2. Inlets are clearly marked on valve body casting. Connect hot water to inlet marked "HOT" and cold water to inlet marked "COLD."
3. Included angle checkstops must be installed on both supply lines (see above).
4. Use solder or pipe cement sparingly. Flush supply pipes before connecting valve. Flush outlet pipe and valve once valve is connected.

Maximum operating pressure is 125 PSI (860 KPA) for hot and cold water. Maximum hot to cold water pressure differential is 5%.

Note: Should piping be exposed to excessive hot or cold conditions, it may be necessary to insulate piping to prevent freezing or scalding water.



IMPORTANT: THESE SYSTEMS ARE DESIGNED TO PROVIDE MIXED WATER FROM 60 TO 90°F (15 TO 32°C) FOR EMERGENCY EYE OR EYE/FACE WASH APPLICATIONS ONLY IN ACCORDANCE WITH ASSE 1071.

Note: This is a control system which must be cleaned and maintained regularly (see Maintenance Guide and Record card included with valve shipment).

Adjustment and Service

WaterSaver Faucet Co. thermostatic mixing valves may be easily cleaned, adjusted and repaired. Servicing may be possible without disconnecting valve.

Note: Thermostatic water mixing valves are regulating mechanisms which must be regularly maintained to provide best performance. Local water quality and usage conditions dictate cleaning frequency. (See Maintenance Guide and Record card included with valve shipment and reference ANSI Z358.1)

To Reset Adjustable High Temperature Limit Stop:

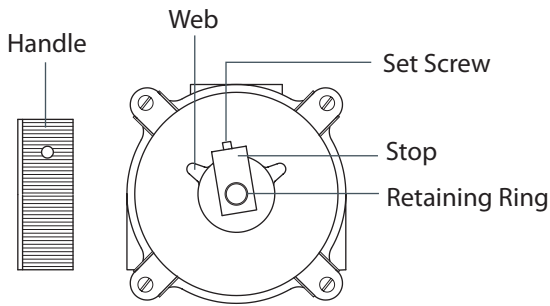

1. Remove handle, retaining ring, loosen set screw, and remove stop.
2. Activate emergency fixture.
3. Replace handle and adjust to reach desired maximum temperature.
Note: Temperatures above 90°F are not recommended. Consult a medical advisor for correct temperature settings.
4. Replace stop such that it rests against the web on the left side of the cover.
5. Tighten set screw and reassemble. Hold a thermometer under water flow to verify maximum temperature has been set appropriately. Then set desired operating temperature.



WARNING: THIS THERMOSTATIC MIXING VALVE HAS AN ADJUSTABLE HIGH TEMPERATURE LIMIT STOP WHICH MUST BE CHECKED. IF TEMPERATURE IS TOO HIGH, THE INSTALLER MUST RESET THIS STOP IMMEDIATELY. ALWAYS CHECK THE TEMPERATURE OF THE MIXED WATER WHEN THE LEVER HANDLE IS TURNED TO FULL HOT. EXCESSIVE HOT WATER TEMPERATURE IS DANGEROUS AND MAY CAUSE SCALDING.

THE HIGH TEMPERATURE LIMIT STOP IS FACTORY SET AT APPROXIMATELY 90°F (32°C) WITH AN INCOMING HOT WATER SUPPLY TEMPERATURE OF 135°F (57°C). IF THE INCOMING HOT WATER TEMPERATURE IS HIGHER THAN 135°F (57°C), THE VALVE (WHEN TURNED TO FULL HOT) WILL DELIVER WATER IN EXCESS OF 90°F (32°C) AND THE HIGH TEMPERATURE LIMIT STOP MUST BE RESET.

Troubleshooting

Symptom	Component Type	Part No.	Description
Leak between valve cover and body.	Packings and Gaskets	6806	Cover Gasket
Leak at lockable dial.	Packings and Gaskets	MU-5A	O-Ring
Valve outlet temperature cannot be adjusted or will not mix consistently.	Port Sleeve Assembly	TAG-1M or RK3600A	Port Sleeve Assembly or Repair Kit
After cleaning or replacing port sleeve assembly, valve will not hold temperature.	Thermostat Group	6810 or RK3600A	Thermostat Group or Repair Kit
Hot water bypass into cold line.	Checkstops	RK3600B	Checkstop Kit
Supplies cannot be shut off completely.	Checkstops		
Leak at checkstop bonnet.	Checkstops		

If installed on a circulated hot water system, verify the valve is piped according to Required Piping Method on page 3.

See page 5 for complete parts breakdown and parts kits.

Note: This is a control system which must be cleaned and maintained regularly (see Maintenance Guide and Record card included with valve shipment).

Required Piping Method

Required when hot water must be circulated to a thermostatic mixing valve that is a substantial distance from the hot water source. Recommended hot water inlet temperature is 135°F (57°C).

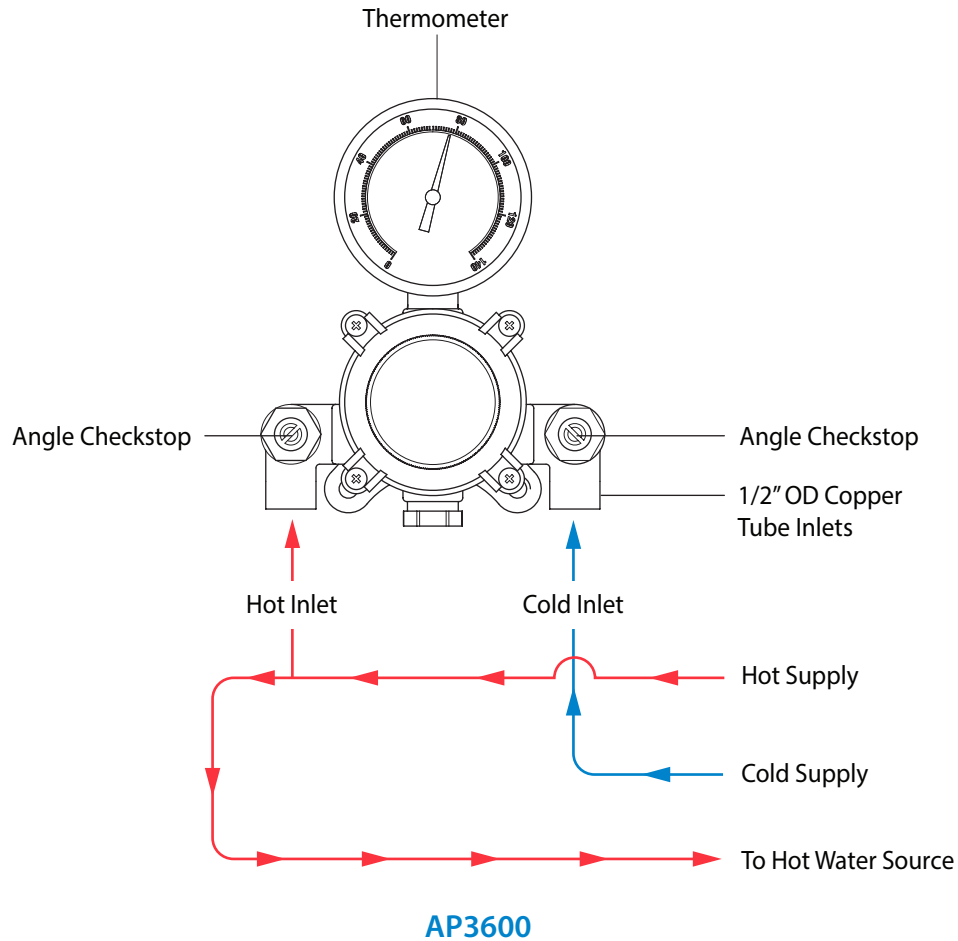

This unit must be cycled each time the emergency equipment is inspected (See ANSI Z358.1, Maintenance and Training section).

1. Set the thermostatic mixing valve to full hot.
2. Activate eye or eye/face wash and verify outlet temperature does not exceed 90°F (32°C).
3. Turn thermostatic valve to full cold and wait ten seconds.
4. Turn thermostatic valve to full hot and wait ten seconds.
5. Verify outlet temperature does not exceed 90°F (32°C).
6. Turn thermostatic mixing valve to full cold and wait ten seconds.
7. If necessary, adjust high temperature limit stop (see page 2). Then set mixing valve to desired operating temperature and deactivate emergency equipment.

Note: This is a control system which must be cleaned and maintained regularly (see Maintenance Guide and Record card included with valve shipment).

To Dismantle Valve:

Turn off hot and cold water supplies to valve. Remove four cover screws and remove cover and thermostat group. (Figure 1) After replacing parts, lockable dial must be reset to obtain correct temperature range from Cold to Hot. (see "To Reset Adjustable High Temperature Limit Stop" on page 2).

To Clean Port Sleeve Assembly:

Remove base stud (Figure 2). Twist port sleeve nut into valve body, slide port sleeve assembly toward port sleeve nut, and lift from valve body to clean. Clean with non-corrosive agent and soft cloth. **DO NOT USE ABRASIVES.** Wash parts thoroughly after cleaning and reassemble. Reinstall port sleeve assembly with long slot end nearest port sleeve nut. Tighten port sleeve nut to complete reassembly. **DO NOT OVERTIGHTEN.**

To Clean Thermostat Group:

Loosen set screw and remove handle (Figure 1). Remove retaining ring and stop. Push rod through cover to remove thermostat group. **DO NOT PULL COILS OUT OF SHAPE.** Use brush and cleaning solution (non-corrosive and grit-free) to remove any deposit build-up from thermostat coil. Wash thoroughly before reassembly.

Reassemble by reinstalling base stud, then place thermostat group 6810 on base stud. **PORT SLEEVE ASSEMBLY DRIVING BALL MUST BE INSERTED INTO HOLE ON LOWER COIL BRACKET**(Figure 3). Verify thermostat moves back and forth. Replace cover and screws and turn hot and cold water supplies on. See page 2 "To Reset Adjustable High Temperature Limit Stop."

*Note: After installation, adjustment, and cleaning, always verify valve temperature with thermometer when turned to full hot. If necessary, adjust temperature of hot water source. **EXCESSIVE HOT WATER TEMPERATURE (OVER 90°F) IS DANGEROUS AND MAY CAUSE SCALDING.***

Figure 1

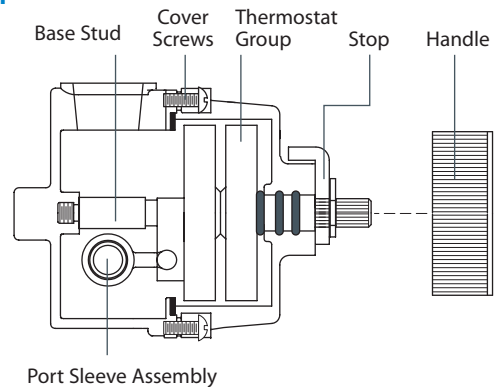

Figure 2

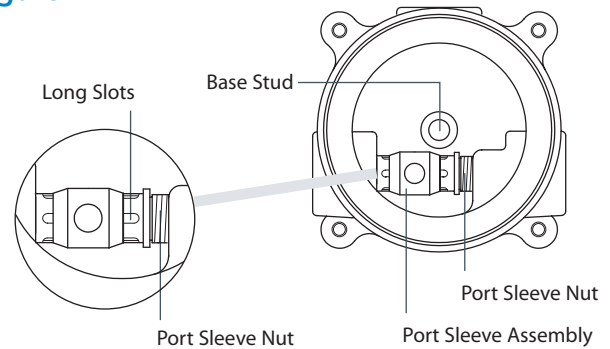
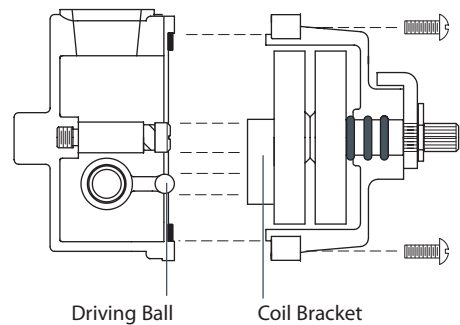
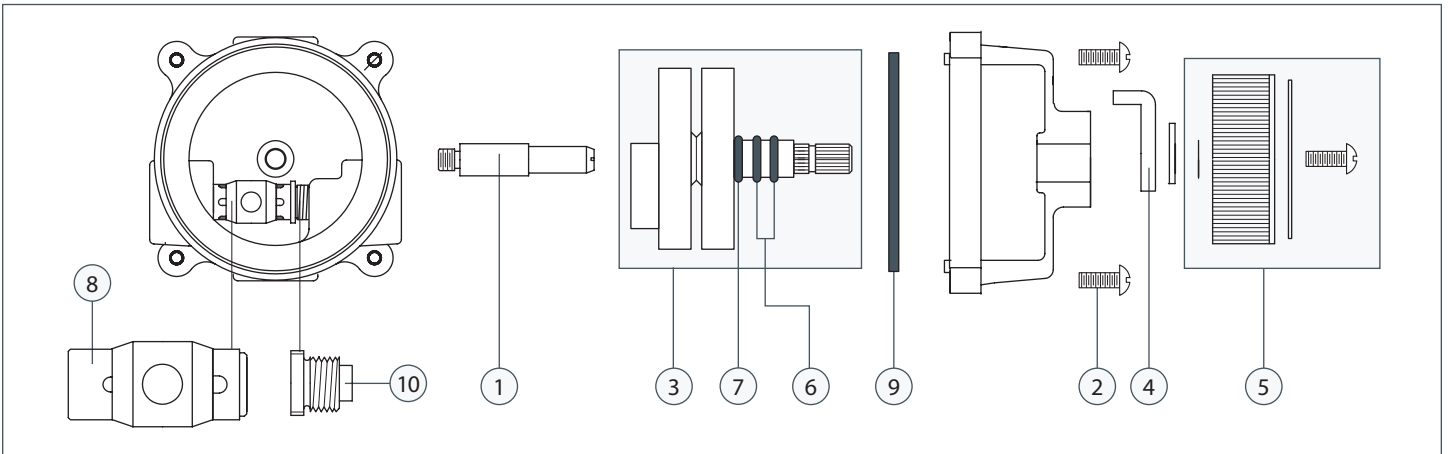

Figure 3



Note: This is a control system which must be cleaned and maintained regularly (see Maintenance Guide and Record card included with valve shipment).

Thermostatic Mixing Valve Parts



Checkstop Parts

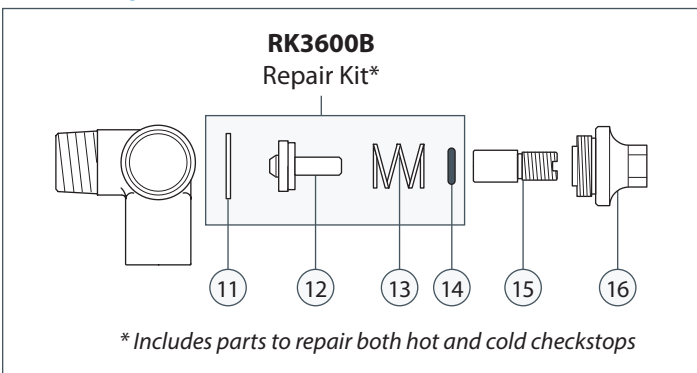

Thermostat Group

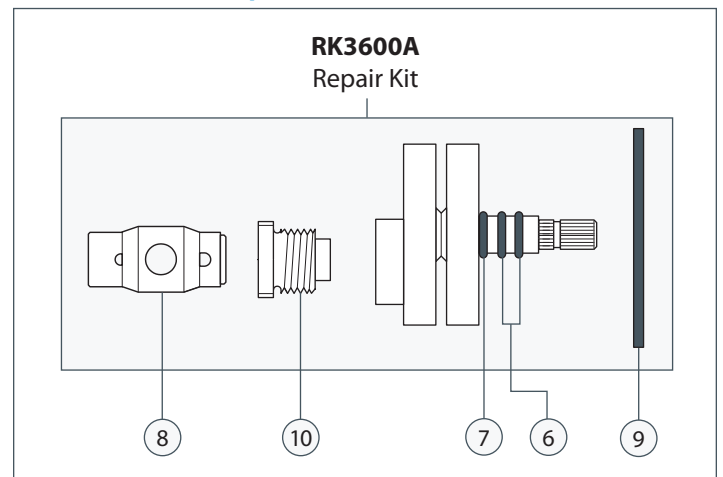

Lockable Dial

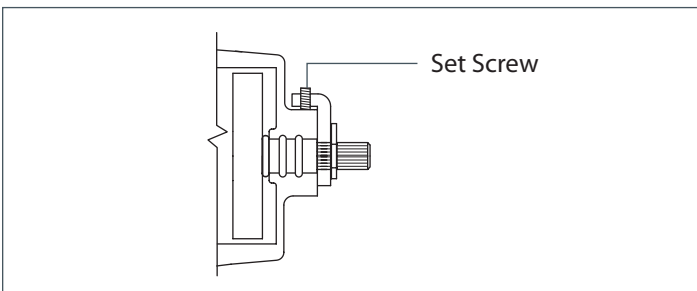

Notes:

1. After installing new parts, the adjustable high temperature limit stop must be reset (see page 2).
2. AP3600 valves are furnished with lockable dials.

Item	Part Number	Description
1	TA-5	Base Stud
2	MU-2C	Cover Screw
3	6810	Thermostat Group
4	6820	Stop
5	68240	Handle
6	MU-5A	Stem O-Ring
7	3009	Cover O-Ring
8	TAG-1M	Port Sleeve Assembly

Item	Part Number	Description
9	6806	Cover Gasket
10	3402	Port Sleeve Nut
11	LVC-8A	Check Bonnet Packing
12	MU-6A	Lower Stem with Packing
13	MU-9A	Check Spring
14	MU-5A	O-Ring
15	MU-4A	Upper Check Stem
16	LVC-7A	Check Bonnet

Note: This is a control system which must be cleaned and maintained regularly (see Maintenance Guide and Record card included with valve shipment).

Flow Capacities

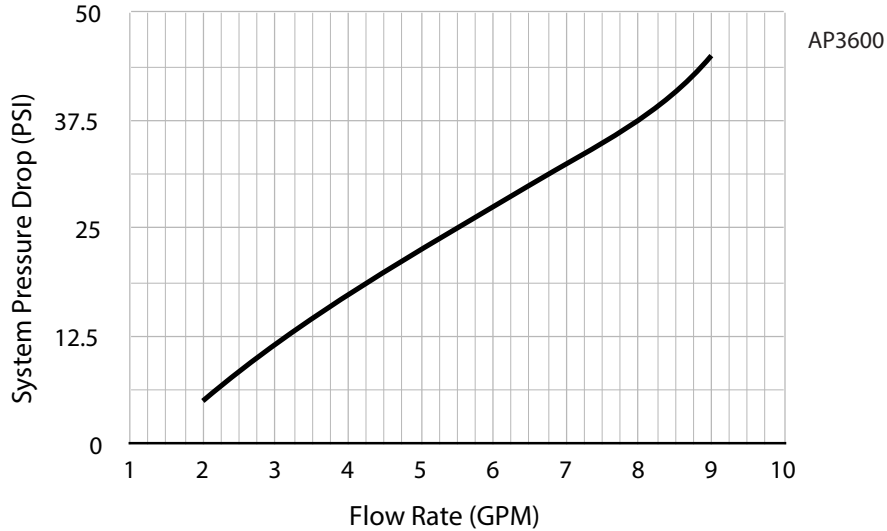

MODEL	IN	OUT	MINIMUM FLOW (GPM)	INTERNAL COLD WATER BYPASS MINIMUM	SYSTEM PRESSURE DROP									
					5	10	15	20	25	30	35	40	45	PSI
			L/MIN		0.3	0.7	1.0	1.4	1.7	2.1	2.4	2.8	3.1	BAR
AP3600	1/2"	1/2"	2	4	2.0	2.7	3.5	4.5	5.5	6.5	7.5	8.5	9.0	GPM
			7.6	15	7.6	10	13	17	21	25	28	32	34	L/MIN
MAXIMUM FLOW CAPACITY														
AP3600 HAS 1/2" NOMINAL SWEAT CONNECTIONS.														



CAUTION: ALL THERMOSTATIC MIXING VALVES HAVE LIMITATIONS. THEY WILL NOT PROVIDE THE DESIRED ACCURACY OUTSIDE OF THEIR FLOW CAPACITY RANGE. CONSULT CAPACITY CHART AND DO NOT OVERSIZE. MINIMUM FLOW MUST BE NO LESS THAN SHOWN ABOVE.



IMPORTANT: THESE SYSTEMS ARE DESIGNED TO PROVIDE MIXED WATER FROM 60 TO 90°F (15 TO 32°C) FOR EYE OR EYE/FACE WASH APPLICATIONS ONLY IN ACCORDANCE WITH ASSE 1071.

Limited Warranty

WaterSaver Faucet Co. warrants the original purchaser that its products will be free from defects in materials and workmanship under normal usage conditions, and when properly installed and maintained according to manufacturer's instructions for a period of two years from date of shipment. During the warranty period, WaterSaver Faucet Co. will (at its discretion) repair or replace any product or part thereof, which shall be returned, freight prepaid to WaterSaver's factory and determined by the manufacturer to be defective in materials or workmanship. There are no warranties, expressed or implied, which extend beyond verbiage contained herein. There are no implied warranties of merchantability or fitness for a particular purpose. WaterSaver Faucet Co. will not be held liable for labor, incidental or consequential damages. Any alteration or improper installation or improper use of the product will void this limited warranty.

Note: This is a control system which must be cleaned and maintained regularly (see Maintenance Guide and Record card included with valve shipment).