

TM6040 Thermostatic Mixing Valve, 50 Gallon/189 Liter Capacity

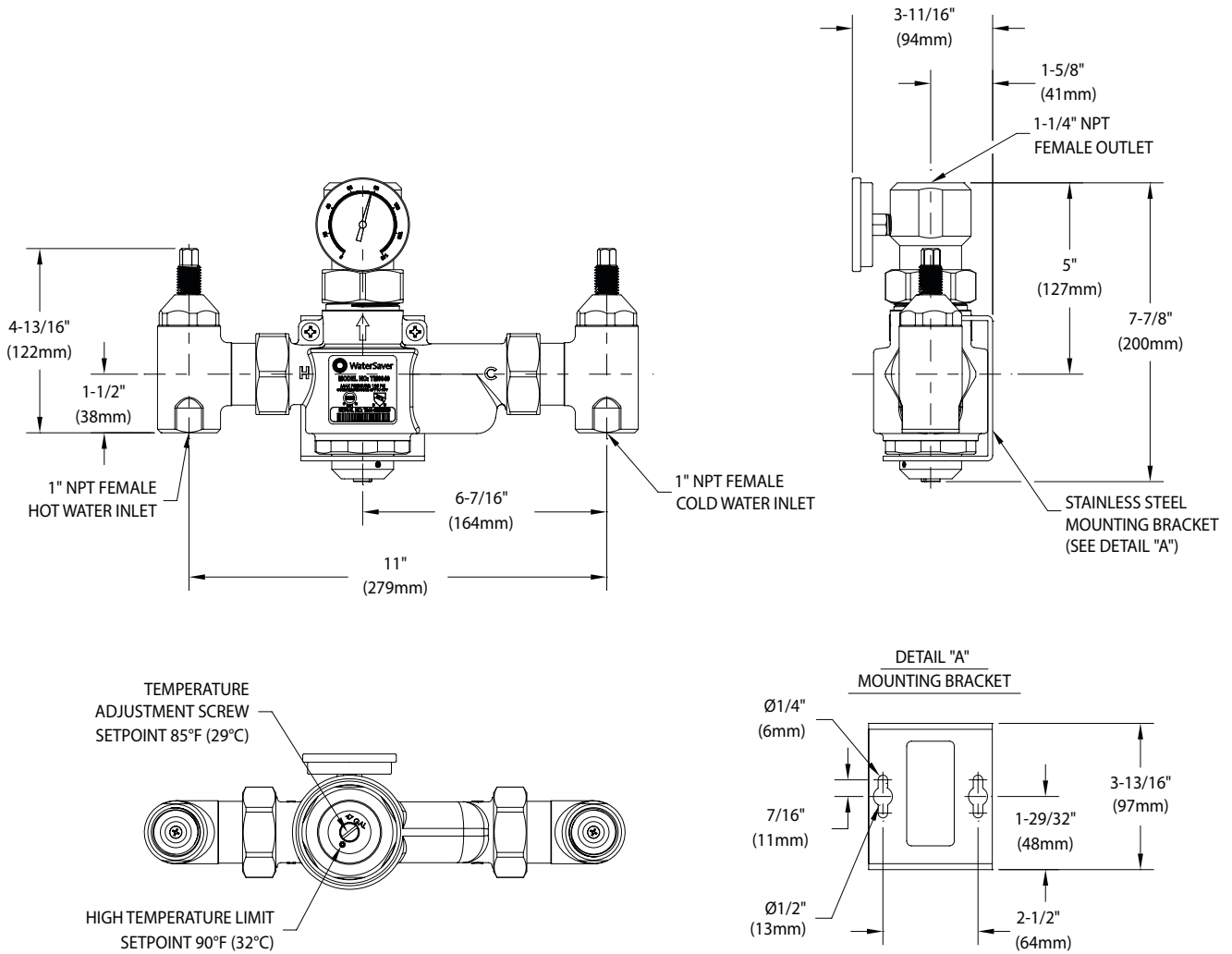

Notes:

- ANSI Z358.1-2014 states that the water temperature delivered by emergency equipment should be “tepid”. Tepid is defined as 60°F - 100°F (16°C - 38°C). However, in circumstances where a chemical reaction can be accelerated by water temperature, a medical professional should be consulted to determine the optimum water temperature for the application.
- For thermostatic mixing valves to deliver the required water temperature and volume, the system must be sized correctly. Please refer to the flow capacity, pressure and temperature requirements herein when designing the tepid water system.
- Valve is factory set to deliver 85°F (29°C) tepid water. Depending on pressure and temperature of the incoming water supplies, this setting may require adjustment in the field. The adjustment screw is locked in position after adjusting.
- Thermostatic mixing valves, like all emergency equipment, must be installed in accordance with the manufacturer’s instructions and maintained on a regular basis. Per ANSI Z358.1-2014, all emergency equipment should be activated weekly and inspected at least annually. Thermostatic mixing valves should be treated the same.
- Per ANSI Z358.1-2014, plumbed emergency equipment must be connected to a potable water supply. This valve meets the requirements of the U.S. Safe Drinking Water Act as lead-free and is safe for use with potable water.
- This valve is supplied with shutoff valves. Per ANSI Z358.1-2014, if shutoff valves are installed on the water supply to emergency equipment, the valves must be lockable to prevent unauthorized shutoff. Accordingly, each shutoff valve stem on this valve has a hole for installing a lock to secure the stem in the open position.

THIS SPACE FOR ARCHITECT/ENGINEER APPROVAL

Due to continuing product improvement, the information contained in this document is subject to change without notice. All dimensions are ± 1/4" (6mm). Rev. 022420

