



# WaterSaver

## ColorTech

### CT5100F-225WSA

LABORATORY WATER VALVE ASSEMBLY, PANEL MOUNTED

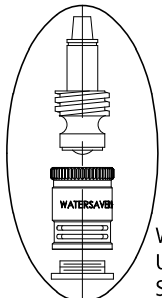
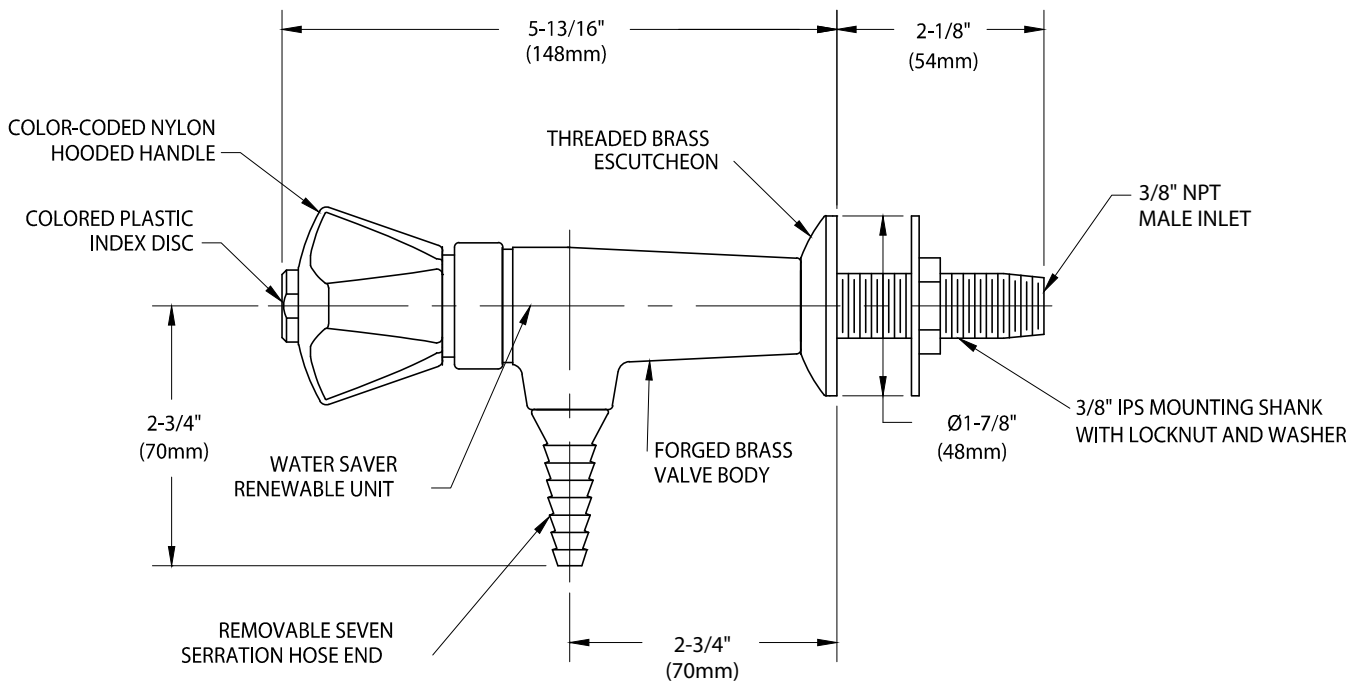

WATER SAVER RENEWABLE UNIT WITH REPLACEABLE STAINLESS STEEL SEAT

MEASUREMENTS MAY VARY ±1/4" (6mm).



#### NOTES:

1. FIXTURE IS CERTIFIED BY CSA INTERNATIONAL TO COMPLY WITH ASME A112.18.1M AND CSA B125.1.
2. FURNISHED WITH THREADED ESCUTCHEON, MOUNTING SHANK, LOCKNUT AND WASHER FOR SECURING FIXTURE TO PANEL.
3. FIXTURE IS FULLY ASSEMBLED AND FACTORY TESTED PRIOR TO SHIPMENT.
4. FIXTURE HAS COLORTECH EPOXY POWDER COATED FINISH. SPECIFY COLOR (WHITE, GRAY OR TAN) WHEN ORDERING.