

G1562HTR-HAT Portable Eyewash/Drench Hose Unit, 15 Gallon, Heated, with Hand Truck

Application: ANSI Z358.1-2014 “Emergency Eyewash and Shower Equipment” requires that the water delivered by an emergency eyewash be “tepid”, which is defined as between 60° and 100° F (15.5°- 37.8° C). The G1562HTR-HAT portable eyewash/drench hose unit is electrically heated and insulated, making it ideal for use in areas where ambient temperatures may drop below the tepid range. In extreme conditions, the heating system will also protect the unit against freezing.

The G1562HTR-HAT heated portable eyewash/drench hose unit uses air pressure to deliver 10 gallons (37.5L) of water for 15 minutes. For use in low hazard areas where a continuous supply of water is not available.

Installation: Unit can be placed in any area where hazards are present. To prepare unit for use, fill with 10 gallons (37.5L) of clean potable water and add bacteriostatic additive (supplied with unit). Bacteriostatic additive protects against growth of bacteria, fungus, algae and acanthamoeba. After filling, pressurize with 80 PSI (5.5 bar) air pressure.

Hand Truck: Unit is mounted on two-wheel hand truck for ease of installation and movement. Hand truck has painted steel frame with handles and (2) rubber wheels. Unit is secured to truck with rubber straps.

Heating System: Silicone drum heater is attached to outside of tank. Thermostat set to 65° F (18.3° C) senses the temperature of the water inside the tank to turn the heater on and off. Heater requires 15 amp, 120 volt power supply. Total amp draw is 3.33 amps. Furnished with 9 ft. cord with ground fault circuit interrupter (GFCI) plug and manual reset.

Exterior Jacket: High visibility orange insulated nylon jacket contains heat to maintain water temperature and protects unit against freezing. Jacket is waterproof and resistant to mildew.

Tank: 15 gallon (56L) stainless steel tank. Tank has built-in carrying handles, air intake valve, pressure gauge and pressure relief valve.

Eyewash: Use to wash user’s eyes for 15 minutes. Furnished with (2) GS-Plus low flow spray heads with “flip top” dust covers, integral flow controls and filters. Valve is ½” IPS chrome plated brass self-draining ball valve with flag handle. User’s hands are free while eyewash is in operation. Self-draining valve allows water to drain out from spray heads after use.

Drench Hose: For rinsing any part of the user’s eyes, face or body. Furnished with single GS-Plus spray head, self-closing valve with handle and 6 foot (2m) reinforced PVC hose

Discharge Time: Eyewash delivers .7 GPM (2.6L/min) for 15 minutes. Drench hose delivers 1.7 GPM (6.4L/min) for 6 minutes. Discharge time is less if eyewash and drench hose are used simultaneously.



Weight: 82 lbs. (37.2kg) empty, 163 lbs. (73.9kg) filled.

Sign: Furnished with ANSI-compliant sign.

Quality Assurance: Unit is assembled and factory tested prior to shipment.

Maintenance: Unit must be inspected regularly. Refill unit after testing or use. Water and bacteriostatic additive must be changed at least once every six months.

Shipping Note: Due to the size of the components, this unit is shipped in two cartons.

Available Options

- G1540BA-R** Case of (4) replacement bottles of bacteriostatic additive.
- AP200-013** Hand truck only.

G1562HTR-HAT Portable Eyewash/Drench Hose Unit, 15 Gallon, Heated, with Hand Truck

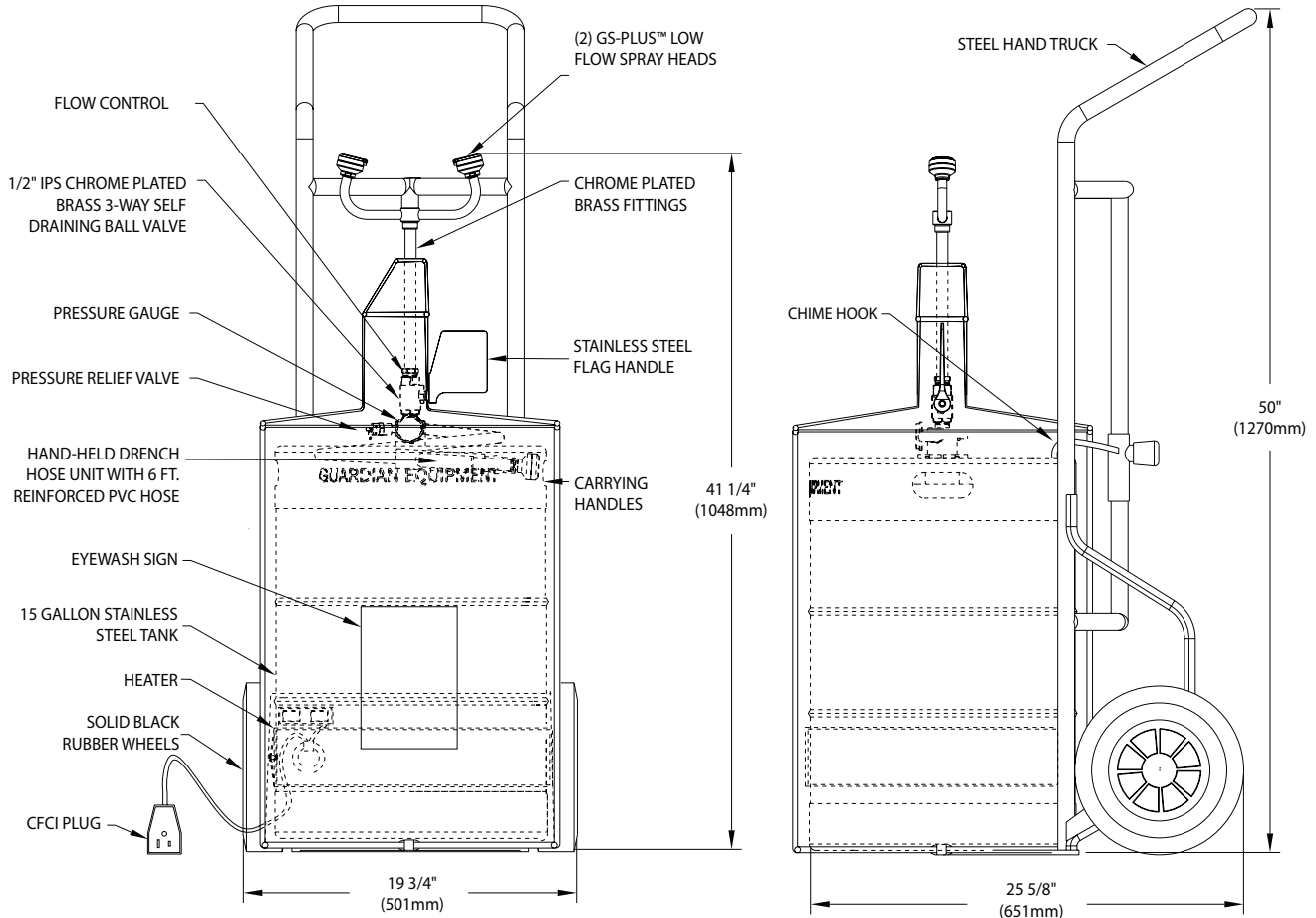

WEIGHT:
 EMPTY: 82 LBS. (37.2KG)
 FULL: 163 LBS. (73.9KG)

EFFECTIVE CAPACITY:
 APPROX. 10 GALLONS (38 L)

ELECTRICAL:
 POWER: 15 AMPS, 120 VAC
 CURRENT DRAW: 3.33 AMPS
 TEMPERATURE SET POINT: 65° F (18° C)

Rev. 031521

THIS SPACE FOR ARCHITECT/ENGINEER APPROVAL

Sign Included



Due to continuing product improvement, the information contained in this document is subject to change without notice. All dimensions are ± 1/4" (6mm). rev. 031521