

○ **L5100F-225WSA-TL** Tin-Lined Laboratory Water Valve Assembly, Panel Mounted

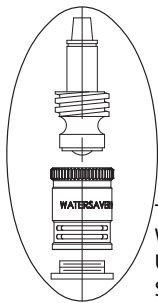
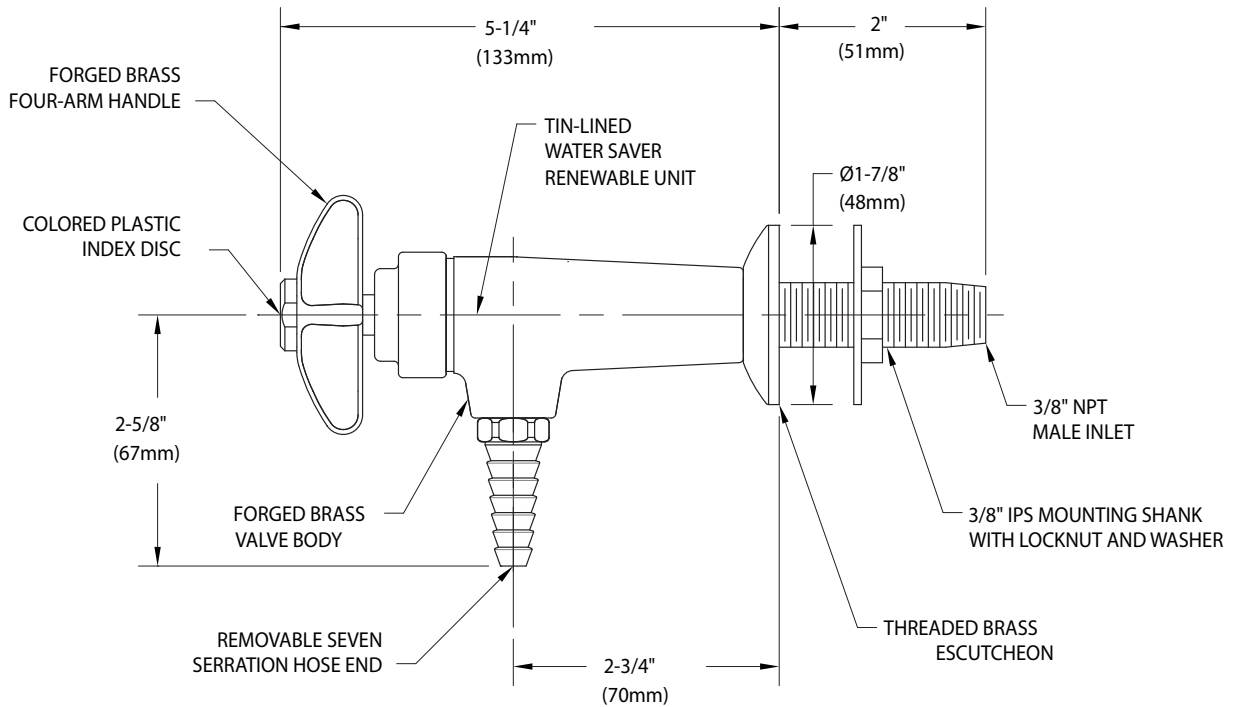

NOTES:

1. FIXTURE IS CERTIFIED BY CSA INTERNATIONAL TO COMPLY WITH ASME A112.18.1M AND CSA B125.1.
2. FURNISHED WITH THREADED ESCUTCHEON, MOUNTING SHANK, LOCKNUT AND WASHER FOR SECURING FIXTURE TO PANEL.
3. FIXTURE IS FULLY ASSEMBLED AND FACTORY TESTED PRIOR TO SHIPMENT.
4. FIXTURE HAS INTERIOR LINING OF PURE TIN.
5. FIXTURE HAS A POLISHED CHROME PLATED FINISH.

Measurements may vary  $\pm 1/4"$ .