

- BT5180F-226WSA** Needle Valve, Wall/Panel Mounted
- BT5280F-226WSA** Needle Valve, Wall/Panel Mounted, Angle Outlet



BT5180F-226WSA



BT5280F-226WSA

**Application:** Flow regulation of all laboratory gases, including special gases such as nitrogen, oxygen, helium and hydrogen. When ordered, valve may be specially cleaned, lubricated and packaged for pure gas service. Valve is certified for natural gas service by CSA International.

**Mounting:** Flanged inlet with locator pins.

**Valve Body:** Angle pattern forged brass.

**Headwork:** Replaceable self-centering stainless steel needle and replaceable stainless steel seat.

**Handle:** Molded nylon hooded style handle with index disc. Handle and index are color coded and marked per EN 13792.

**Inlet:** Furnished with G1/2 mounting shank, locknut and washer. G1/2 male inlet.

**Outlet:** G3/8 female outlet. Furnished with removable straight serrated hose end, quick connect fitting or compression fitting, as ordered (see below).

**Quality Assurance:** Fitting is fully assembled and factory tested prior to shipment. 17 bar (250 PSI) nitrogen test pressure and 10 bar (150 PSI) maximum working pressure.

### Ordering Information

Outlet Fitting Options	BT5180F	BT5280F
Serrated hose end	<input type="checkbox"/> BT5180F-226WSA	<input type="checkbox"/> BT5280F-226WSA
G3/8 quick connect fitting	<input type="checkbox"/> BT5183F-226WSA	<input type="checkbox"/> BT5283F-226WSA
10mm OD compression fitting	<input type="checkbox"/> BT5184F-226WSA	<input type="checkbox"/> BT5284F-226WSA

**Note:** If fitting is to be cleaned for oxygen and pure gas service, add suffix "CLN" to model number.

### Product Finish

<input type="checkbox"/> WHT	Gloss white powder coated finish	<input type="checkbox"/> PCL	Polished chrome plated finish with clear epoxy coating
<input type="checkbox"/> GRY	Gloss light gray powder coated finish	<input type="checkbox"/> SCC	Satin chrome plated finish with clear epoxy coating
<input type="checkbox"/> GRD	Gloss dark gray powder coated finish	<input type="checkbox"/> SNC	Satin nickel plated finish with clear epoxy coating
<input type="checkbox"/> STM	Starburst metallic powder coated finish		

**Note:** Refer to "Product Finishes" catalog for complete information on finishes.

### Media

\_\_\_\_\_

**BT5180F-226WSA** Needle Valve, Wall/Panel Mounted

**BT5280F-226WSA** Needle Valve, Wall/Panel Mounted, Angle Outlet

**BT5180F-226WSA**

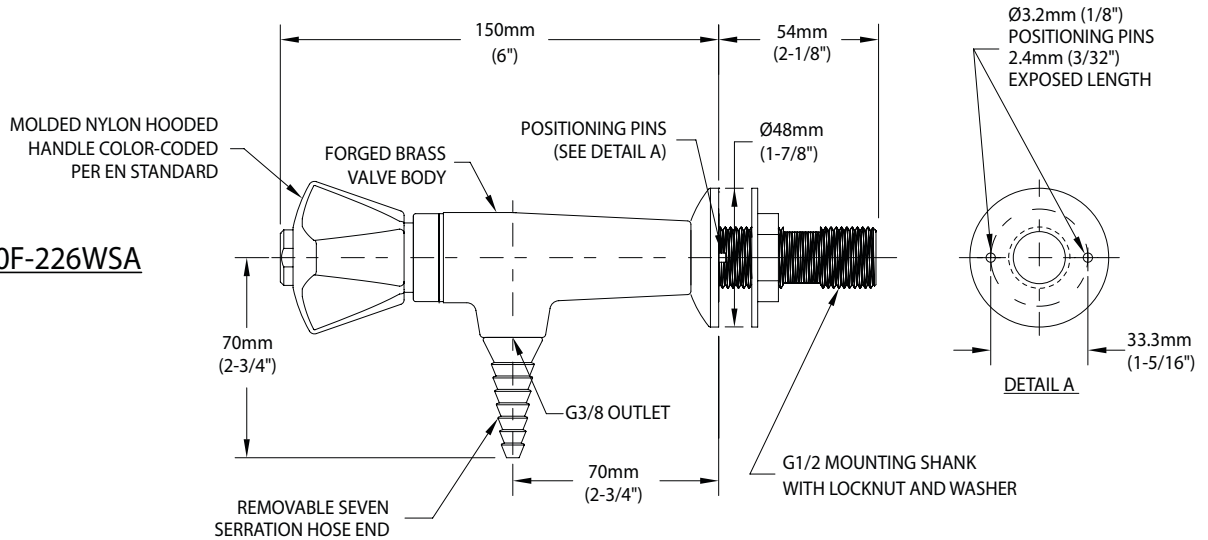

**BT5280F-226WSA**

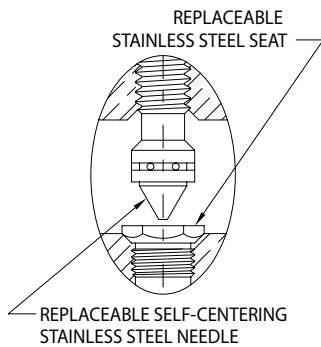
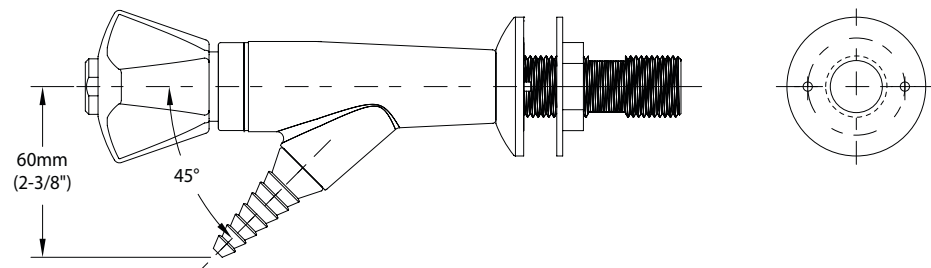

**NOTES:**

1. FURNISHED WITH THREADED ESCUTCHEON, MOUNTING SHANK, LOCKNUT AND WASHER FOR SECURING TO PANEL.
2. FITTING IS FACTORY ASSEMBLED AND TESTED AT 17 BAR (250 PSI). MAXIMUM WORKING PRESSURE IS 10 BAR (150 PSI).
3. IF CLEANING FOR OXYGEN AND HIGH PURITY GASES IS REQUIRED, ADD SUFFIX "CLN".

Rev. 052318

THIS SPACE FOR ARCHITECT/ENGINEER APPROVAL

Due to continuing product improvement, the information contained in this document is subject to change without notice. All dimensions are  $\pm 6\text{mm}$  (1/4"). Rev. 052218